

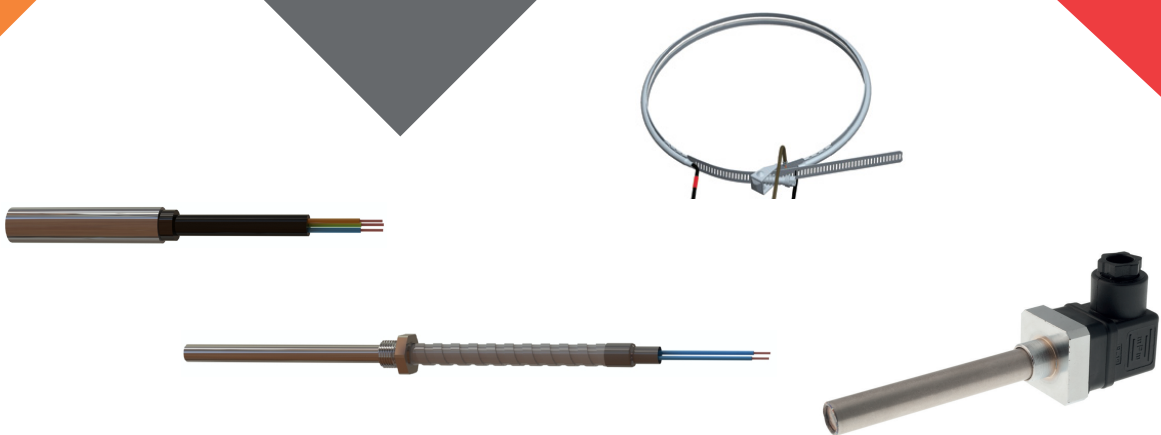

HEATERS FOR COMPRESSORS



APPLICATIONS:



CARTRIDGE HEATERS

The HT's cartridge heaters are traditional heaters with constant power.



| CODE | DIAMETER | HEATER LENGTH | WATT | VOLTAGE | CABLE LENGTH |
|---------|----------|---------------|------|---------|--------------|
| HT76092 | 9,6 | 80 | 50 | 230 | 1100 |
| HT76091 | 9,6 | 95 | 70 | 230 | 1100 |
| HT76090 | 10 | 200 | 150 | 230 | 1100 |
| HT76327 | 15 | 50 | 80 | 24 | 1000 |
| HT76328 | 15 | 50 | 80 | 75 | 1000 |
| HT76329 | 15 | 50 | 80 | 400 | 1000 |

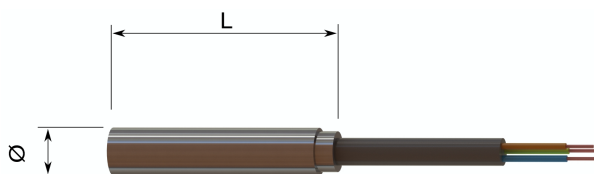

| CODE | DIAMETER | HEATER LENGTH | WATT | VOLTAGE | CABLE LENGTH |
|---------|----------|---------------|------|---------|--------------|
| HT76093 | 12,7 | 70 | 100 | 220/240 | 1000 |
| HT76094 | 12,7 | 70 | 200 | 220/240 | 1000 |
| HT76096 | 12,7 | 76 | 100 | 480 | 2000 |

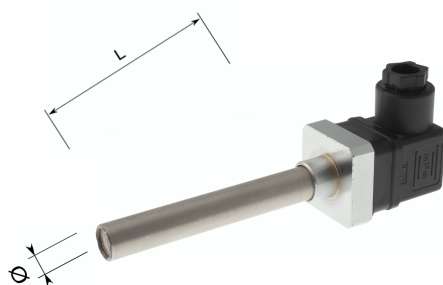

MPM
connector

| CODE | DIAMETER Ø | HEATER LENGTH | WATT | VOLTAGE |
|---------|---------------|---------------|------|---------|
| HT76330 | 9,5 | 105 | 65 | 240 |
| HT76331 | 10 | 200 | 150 | 230 |
| HT76332 | 12,7 | 76 | 100 | 400 |
| HT76333 | 12,7 | 76 | 200 | 400 |

COMPRESSORS HEATERS

The Compressors heaters work in the hole placed in the semi-hermetic compressors or in direct contact with oil. They are used for keeping the refrigerated liquids separated from the lubricating oil.

The Compressors heaters line is thought to simplify the substitution of cartridge heaters for compressors already installed. The compressors heaters are suitable for many models, but they are not original spare parts.

The HT compressors heaters are produced and tested according to the EN60335 standard.

Compliance with the 2014/35/EU Directive.

Available certification : CE ; UL/CSA (available for defined models).

SELF REGULATING PTC HEATERS

The self-regulating cartridge heaters contain a PTC (Positive Temperature Coefficient) ceramic component. The main feature of these components is self-regulating: they reach their maximum power with low temperatures and when the temperatures increases, they reduce their consumption. This type of heaters is suitable for direct contact with the liquid or positioned inside a manifold tube with max internal tolerance of +0,1 mm.

Performance water-air@230V

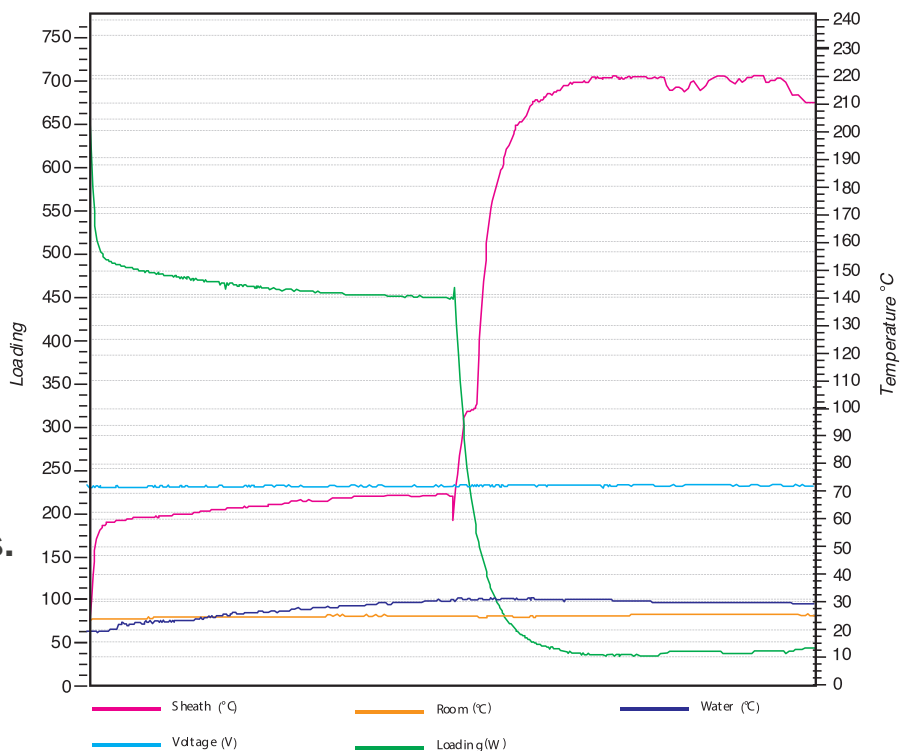

BENEFITS:

- Energy savings,
- High performances,
- Easy, fast assembly,
- No need of temperature controls.

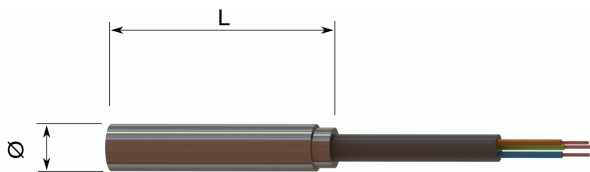

| CODE | DIAMETER Ø | HEATER LENGTH | WATT | VOLTAGE | CABLE LENGTH |
|---------|------------|---------------|------|---------|--------------|
| PT76074 | 12,5 | 70 | 100 | 220/260 | 1000 |
| PT76075 | 12,5 | 70 | 200 | 220/260 | 1000 |
| PT76073 | 12,7 | 86 | 100 | 400 | 3000 |

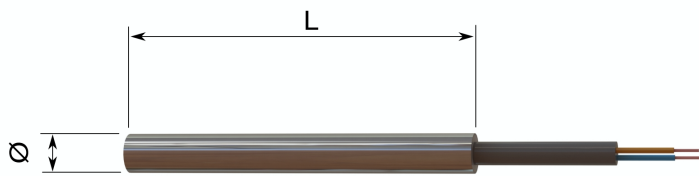

| CODE | DIAMETER Ø | HEATER LENGTH (L) | WATT | VOLTAGE | CABLE LENGTH |
|---------|------------|-------------------|------|---------|--------------|
| PT76076 | 11 | 95 | 60 | 220/260 | 1000 |
| PT76077 | 11 | 113 | 120 | 220/260 | 1000 |
| PT76078 | 11 | 162 | 140 | 220/260 | 1000 |
| PT76079 | 10 | 78 | 50 | 220/260 | 1000 |
| PT76080 | 10 | 93 | 70 | 220/260 | 1000 |
| PT76081 | 10 | 220 | 150 | 220/260 | 1000 |

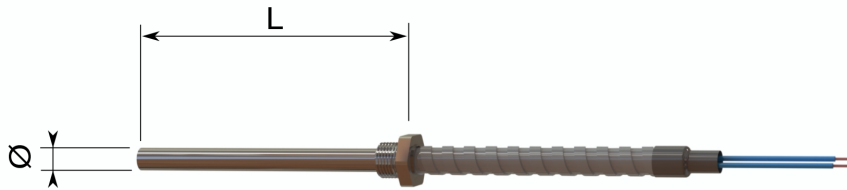

| CODE | DIAMETER Ø | HEATER LENGTH (L) | WATT | VOLTAGE | CABLE LENGTH | NOTE |
|---------|------------|-------------------|------|---------|--------------|------------|
| PT76082 | 10 | 68 | 70 | 220/260 | 1000 | 3/8"18NPTF |
| PT76083 | 10 | 112 | 70 | 220/260 | 1000 | 3/8"18NPTF |
| PT76084 | 10 | 125 | 100 | 220/260 | 1000 | 1/2"14NPTF |

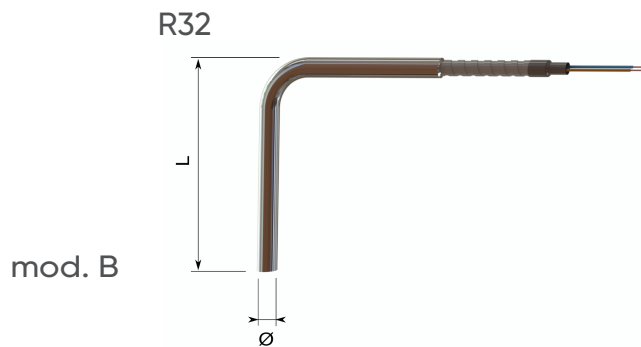
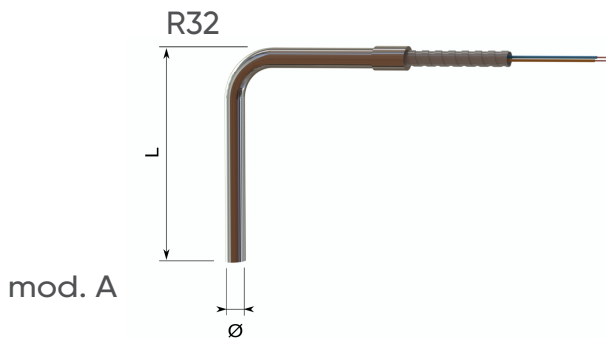

| CODE | DIAMETER Ø | HEATER LENGTH (L) | WATT | VOLTAGE | CABLE LENGTH |
|-------------------|------------|-------------------|------|---------|--------------|
| PT76085 mod. A | 10 | 170 | 100 | 220/260 | 1000 |
| PT76087 mod. B | 12 | 200 | 200 | 220/260 | 1000 |
| PT76088 mod. B | 12,7 | 170 | 180 | 220/260 | 1000 |

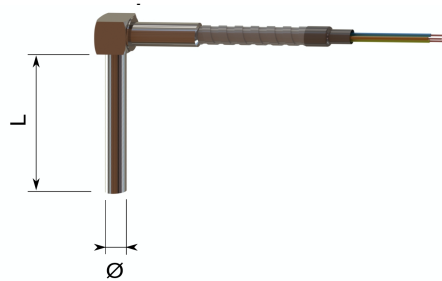

| CODE | DIAMETER Ø | HEATER LENGTH (L) | WATT | VOLTAGE | CABLE LENGTH |
|---------|------------|-------------------|------|---------|--------------|
| PT76086 | 12 | 200 | 200 | 220/260 | 1000 |

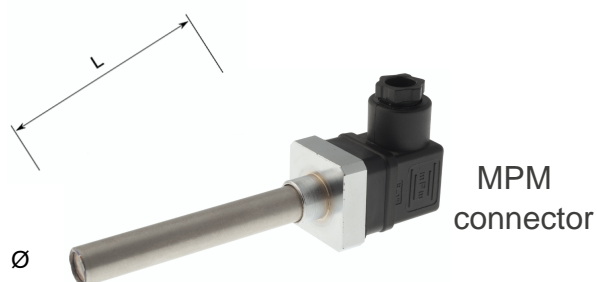

| CODE | DIAMETER Ø | HEATER LENGTH (L) | WATT | VOLTAGE |
|---------|------------|-------------------|------|---------|
| PT76089 | 12 | 300 | 300 | 230 |

CRANKCASE HEATERS

The HT's crankcase heaters are supplied with a shell of aluminium and a constant power. Voltage 220/240. The main purpose is to avoid starts with cold oil in the crank case as a result prolong the life time of the compressor.



| CODE | DIAMETER | DIAMETER MIN/ MAX | WATT |
|---------|----------|-------------------|------|
| CM76097 | 139 | 124 - 178 | 40 |
| CM76098 | 168 | 165 - 200 | 40 |
| CM76099 | 186 | 172 - 226 | 70 |
| CM76100 | 233 | 227 - 281 | 90 |



HT Spa

Via Conegliano, 73/B - 31058 Susegana (TV) - Italy
DOMESTIC SALES - Tel. +39 0438 454294 - vendite@htspa.it
EXPORT SALES - Tel. +39 0438 454290 - sales@htspa.it
Fax +39 0438 62788
www.htspa.it

HT Heizelemente Deutschland GmbH

Tel: +49 5207 99 12 29 0 - Fax: +49 5207 99 12 29 19
info@ht-heizelemente.de
www.ht-heizelemente.de

HT SpA reserves the right to change at any time specification and other information included in this catalogue without notice.